

Mounting the High Volume Paper Roll Supply (RHU-T900)

1. Unpacking : Confirm that all accessories are included.

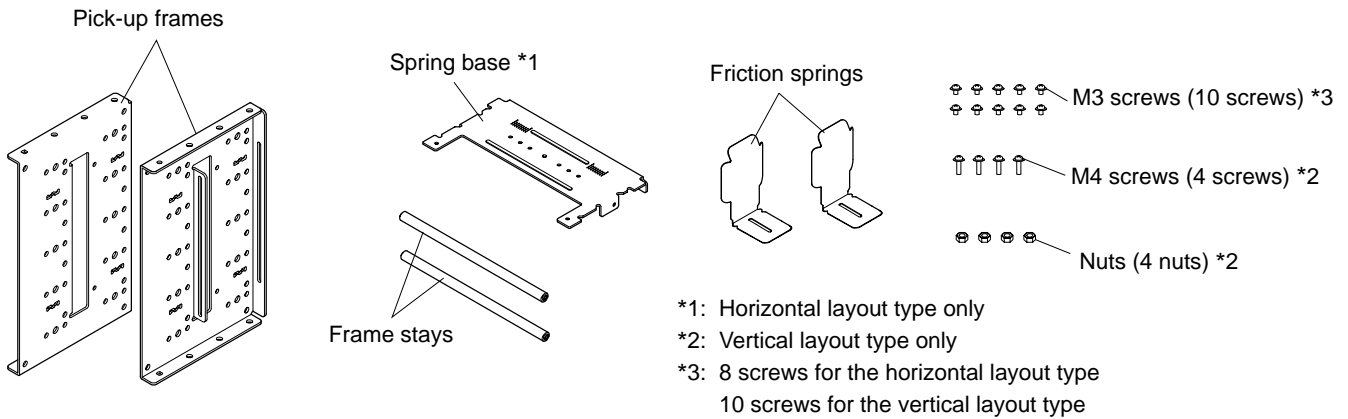

2. Assembling the High Volume Paper Roll Supply (RHU-T900)

The method used to assemble the high volume paper roll supply differs according to whether you are using the printer unit and high volume paper roll supply with a vertical or horizontal layout. Follow the directions for assembly below.

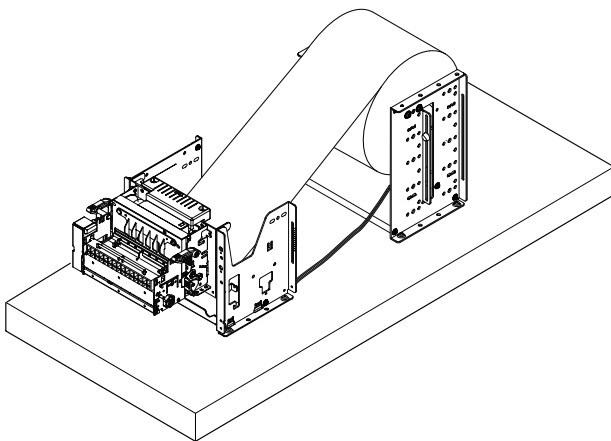

FIG.2-A Horizontal Layout Type

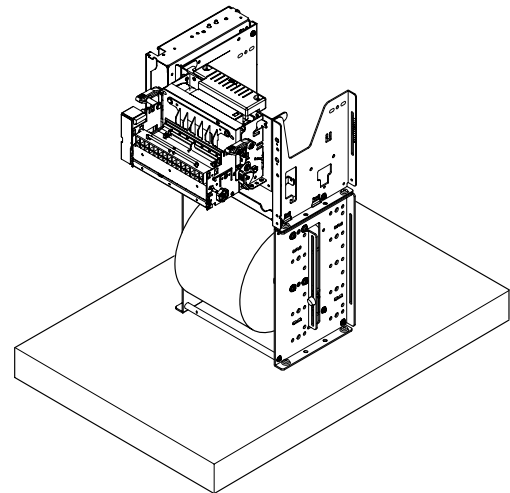

FIG.2-B Vertical Layout Type

2-1 Assembling the Horizontal Layout Type

2-1-1 Assembling the Frame

Use the six M3 screws to mount the pick-up frame (2 pcs.) the spring base and frame stay (2 pcs.).

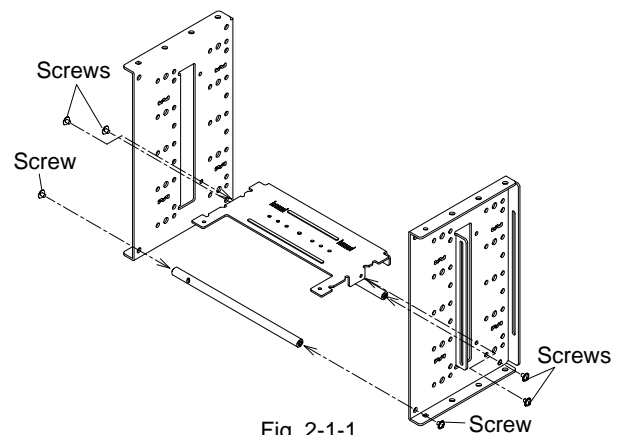

Fig. 2-1-1

2-1-2 Assembling the Friction Spring

Use the four M3 screws to mount the friction spring (2 pcs.).

It is necessary to adjust the mounting position of the friction spring for the width of the paper to be used. See section 8.4 Mounting the Friction Spring in the product specifications manual for details on how to make the adjustments.

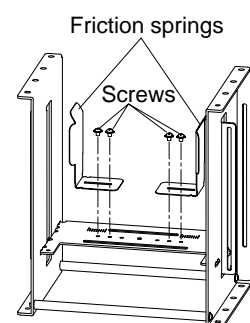

Fig. 2-1-2

2-1-3 Assembling the Bushing Unit

Mount the bushing and bushing unit to the left and right frames. However, the bushing, bushing unit, screws and nuts are not included with the high volume paper roll supply. Use the parts that came with the printer unit. There are several holes in the left and right frames to allow you to select the position to arrange the paper roll. However, the largest diameter paper roll can be mounted at the position shown in the illustration at right. We recommend mounting to this position.

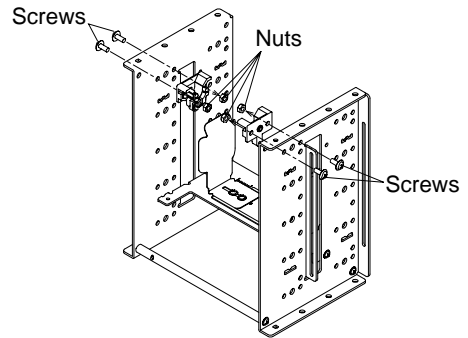

Fig. 2-1-3

2-1-4 Assembling the Paper Near End Sensor

Mount the near end sensor using the fastening screw. However, the near end sensor and fastening screws are not included with the high volume paper roll supply. Use the parts that came with the printer unit. See section 8.5 in the product specifications manual for details regarding the near-end sensor adjustment position.

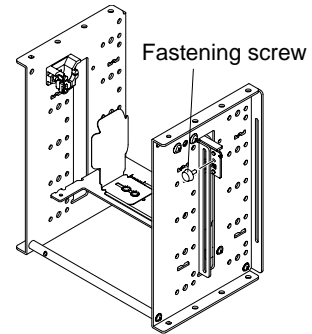

Fig. 2-1-4

2-1-5 Wiring

The cable coming from the near end sensor unit should be arranged so that it does not interfere with the paper roll.

The illustration at right shows the recommended cable layout and connections using the fastener.

Note that the fastener is not included. This should be prepared by the customer.

Cautions in laying out cables:

Layout the cables so that they are not cut by the sharp edges in the frame.

Note: Consider the bundling of the wires and the length to determine the position to arrange the near end sensor.

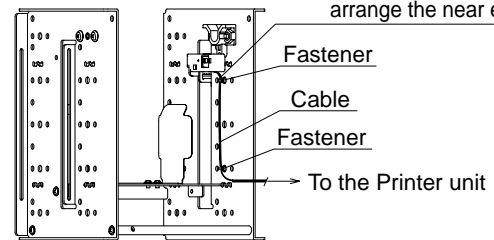

Fig. 2-1-5

2-2 Assembling the Vertical Layout Type

2-2-1 Assembling the Frame

Use the four M3 screws to mount the pick-up frame (2 pcs.) and the frame stay (2 pcs.).

The spring base is not necessary to be mounted to the high volume paper roll supply, when using the vertical layout type. It is necessary to mount on the user side frame. See section 8.4 Mounting the Friction Spring in the TUP900 product specifications manual for details regarding mounting.

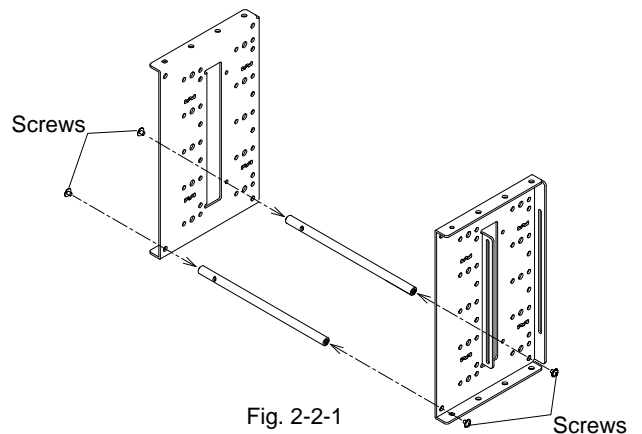

Fig. 2-2-1

2-2-2 Assembling the Bushing Unit

Mount the bushing and bushing unit to the left and right frames. However, the bushing, bushing unit, screws and nuts are not included with the high volume paper roll supply. Use the parts that came with the printer unit. There are several holes in the left and right frames to allow you to select the position to arrange the paper roll. However, the largest diameter paper roll can be mounted at the position shown in the illustration at right. We recommend mounting to this position.

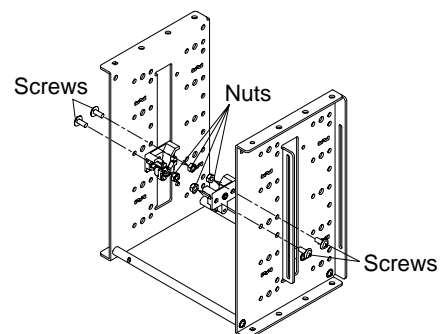

Fig. 2-2-2

2-2-3 Assembling the Paper Near End Sensor

Mount the near end sensor using the fastening screw. However, the near end sensor and fastening screws are not included with the high volume paper roll supply. Use the parts that came with the printer unit. See section 8.5 in the product specifications manual for details regarding the near-end sensor adjustment position.

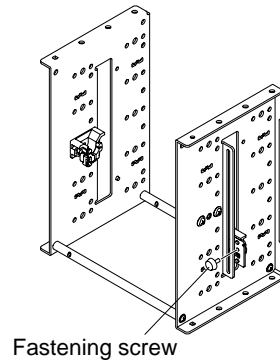

Fig. 2-2-3

2-2-4 Wiring

The cable coming from the near end sensor unit should be arranged so that it does not interfere with the paper roll.

The illustration at right shows the recommended cable layout and connections using the fastener. Note that the fastener is not included. This should be prepared by the customer.

The control board unit position is changed at item 2-2-6. Adjust the length of the cable after changing the position of the control board unit.

Cautions in laying out cables:

Layout the cables so that they are not cut by the sharp edges in the frame.

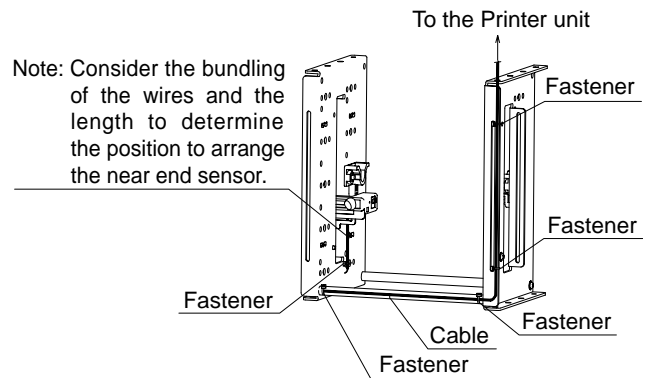

Fig. 2-2-4

2-2-5 Mounting the High Volume Paper Roll Supply

Mount the high volume paper roll supply to the printer unit using the four M4 screws and the four nuts.

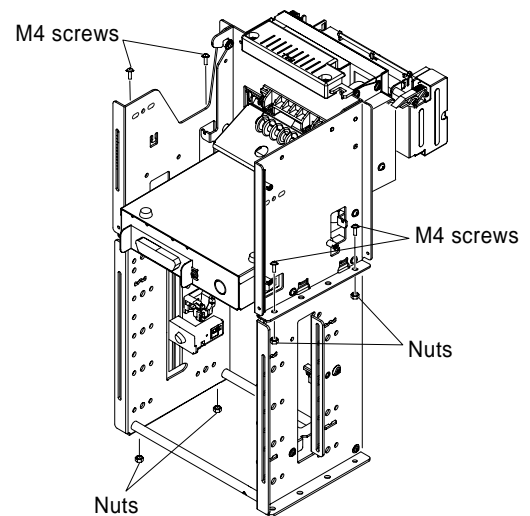

Fig. 2-2-5

2-2-6 Changing the Control Board Unit Layout

Use the following procedures to remove the control board unit that is mounted in the printer unit, and remount it on the printer side.

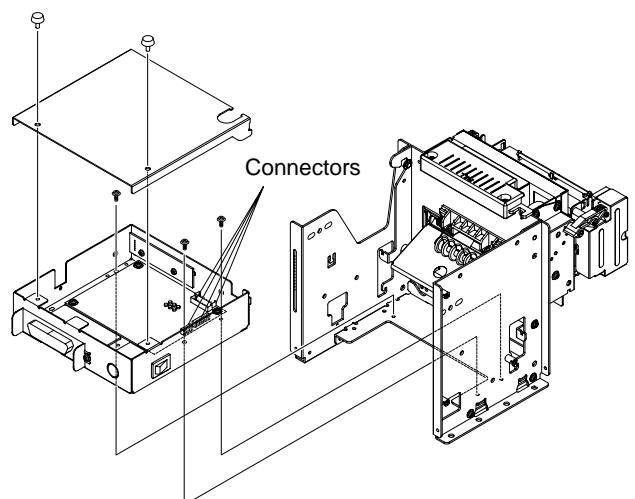

Fig. 2-2-6

1. Remove the two plastic screws to remove the cover.
2. Remove the three screws to remove the control board unit.
3. Remove the cables from the four connectors.
4. Use the screws that you removed to remount the control board unit on the printer unit side. However, the position of the screw holes is different from the time they were removed. See the figure at right to mount.
5. Reverse the procedures to insert the cable into the four connectors and mount the cover.
6. Layout the cable, and if necessary, use a fastener to mount the cable.

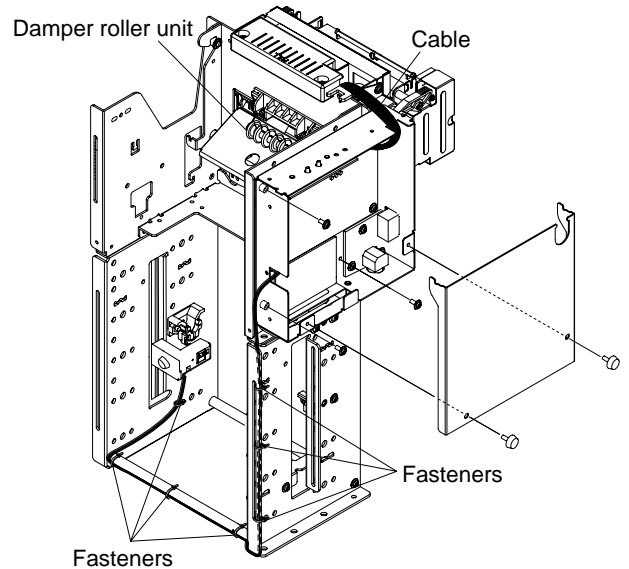

Fig. 2-2-7

2-2-7 Changing the Position of the Damper Roller Unit

Use the following procedures to remove the damper roller unit that is mounted in the printer unit, and change it to a different position for the vertical layout type.

1. Remove the two screws to remove the damper roller unit.
2. Remove the two screws and remove the spring.
3. Insert the leading end of the spring into the groove for the vertical layout type, as shown in the drawing, and change the spring mounting angle.
4. Use the screws that you removed in step 3 to remount the spring.
5. Use the screws that you removed in step 1 to remount the damper roller unit in the new position for the vertical layout type.
At this time, be careful about the direction of the damper roller unit. (See the Fig.2-2-10.)

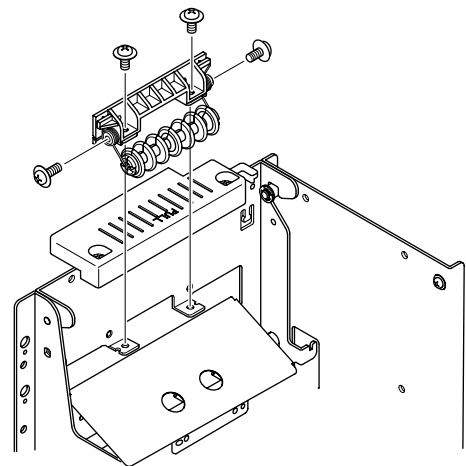
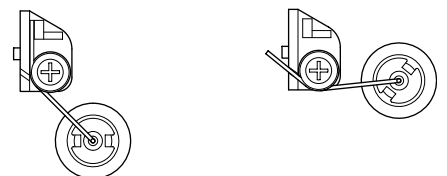

Fig. 2-2-8



Before the change

After the change

Fig. 2-2-9

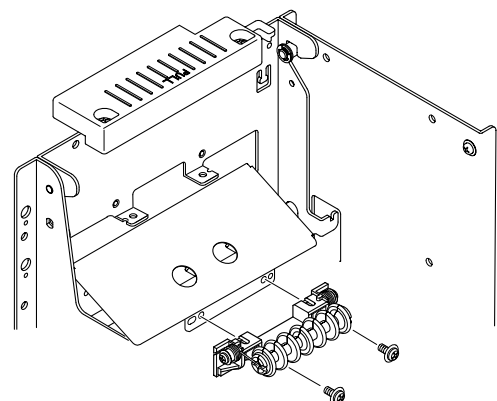

Fig. 2-2-10

3. Setting the High Volume Paper Roll Supply

Use the four screws to mount the high volume paper roll supply to the user side frame. (See the Fig.2-A and 2-B.) Note that the screws are not included. This should be prepared by the customer. See section 8.1 in the product specifications manual for details.